

- Besserer Luftqualität

- Trockene Böden

- Höhere Leistung

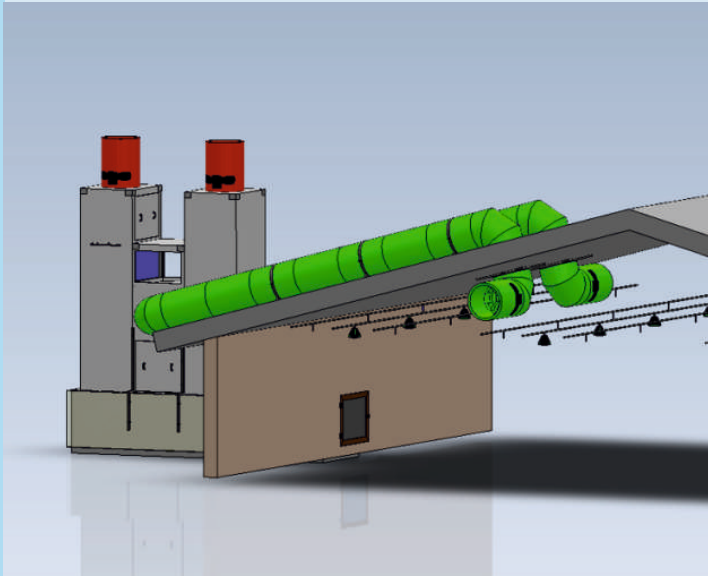

- Weniger CO² Ausstoß, CO² Reduktion im Stall und weniger Energiekosten

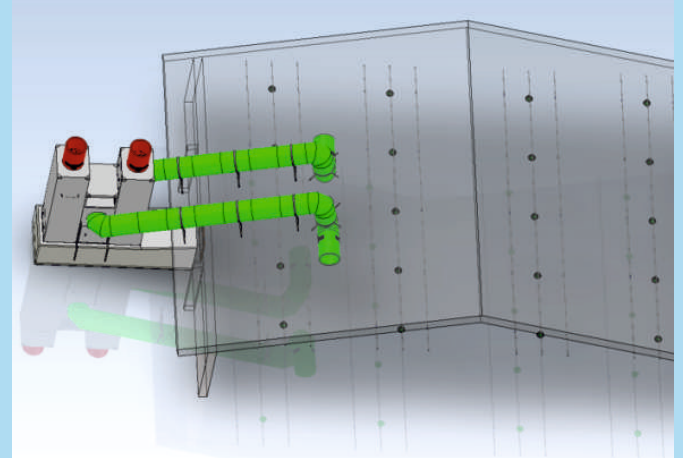
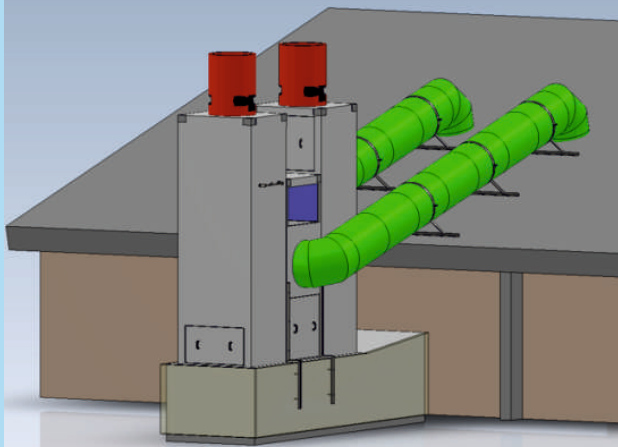

WT-MFK 100 mit 2 Modulen

Der hdt-MFK Wirbelstromtauscher: Der Leistungsstärkste!

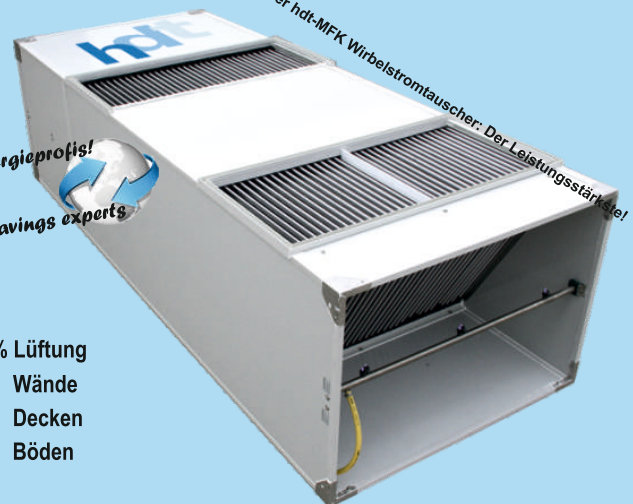

Die Energieprofis!
Energy savings experts

Energie sparen -

unsere beste Energiequelle !

